

60 kHz Repetition Rate NanoSpeed™ Switch Driver

(1x1, 1x2, 2x1 Dual Stage/High Power standard)

(Protected by U.S. patent 7,403,677B1 and pending patents)



DATASHEET

BUY NOW



Features

- High speed
- High repetition
- High output voltage
- Wide input voltage range
- TTL/CMOS control
- Push-Pull output design
- Low power consumption
- Compact and low cost

Applications

- Optical Switch
- EO device driver

The NS switch driver provides a convenient way to use the NS series electro-optical switches, which act as a pure capacitive load. Each driver is tuned to a specific device mounted on the PCB. To operate, the customer only needs to plug in the accompanying DC power supply and input a control signal through the golden SMA connector. The switch will be activated as the input voltage exceeds 3V with less than 1 μ A draw, compatible with 3.3V CMOS/TTL. We produce boards to control multiple NS switches with individual SMA connectors. No computer-based control software is available for such a high-speed operation.

The dual-stage configuration increases the extinction ratio or cross-talk value.

Specifications

Parameter	Min	Typical	Max	Unit
Rise Time (Tr) ^[1]		85	100	ns
Fall Time (Tf) ^[2]		85	100	ns
Repetition Rate	DC		60	kHz
Pulse Width	1.0			μ s
Control Input (TTL pulse)	0		5	V
Power Consumption			5	W
Power Current	0.08		0.4	A
Power Supply		12		V
Operating Temperature	-5		70	°C
Storage Temperature	-40		80	°C
Electrical Connector	SMA			

Note:

[1] Optic Intensity Change from 10% to 90% intuit;

[2] Optic Intensity Change from 90% to 10% intuit;

[3] Switch Speed (Rise): Duration from begin of electronic signal to end of optic intensity change;

[4] Switch Speed (Fall): Duration from begin of electronic signal to end of optic intensity change.

Warning: Control Signal >5.5V Will Damage the Board

Warning: This is an OEM module designed for system integration. Do not touch the PCB by hand. The electrical static can kill the chips even without a power plug-in. Unpleasant electrical shock may also be felt. For laboratory use, please buy a Turnkey system.

Legal notices: All product information is believed to be accurate and is subject to change without notice. Information contained herein shall legally bind Agiltron only if it is specifically incorporated into the terms and conditions of a sales agreement. Some specific combinations of options may not be available. The user assumes all risks and liability whatsoever in connection with the use of a product or its application.

Rev 12/19/23

60 kHz Repetition Rate NanoSpeed™ Switch Driver

(1x1, 1x2, 2x1 Dual Stage/High Power standard)



DATASHEET

Response Measurement

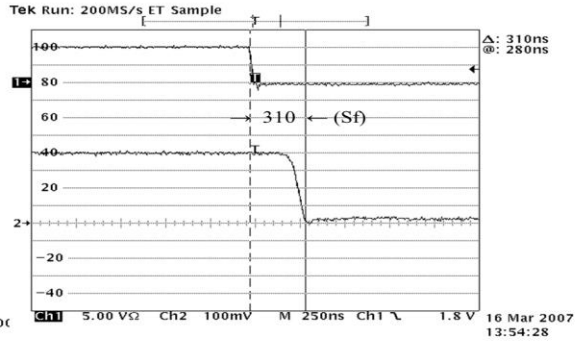
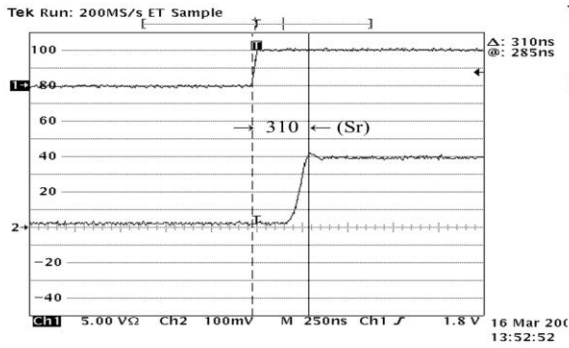
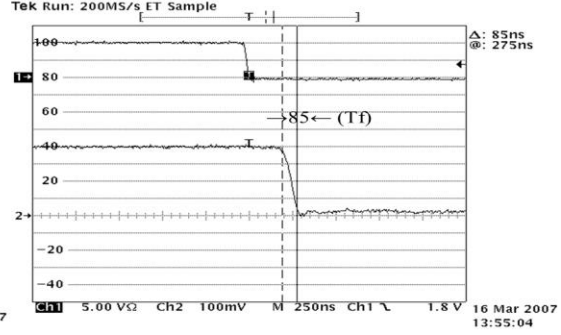
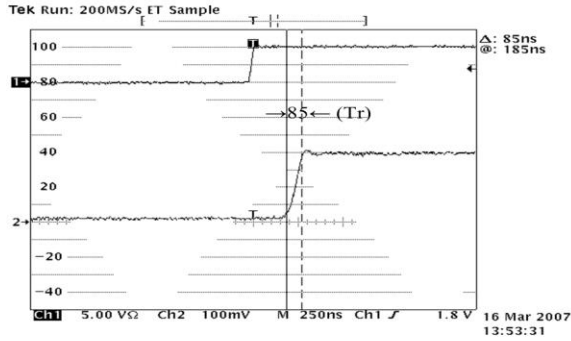

Dimensions (mm)

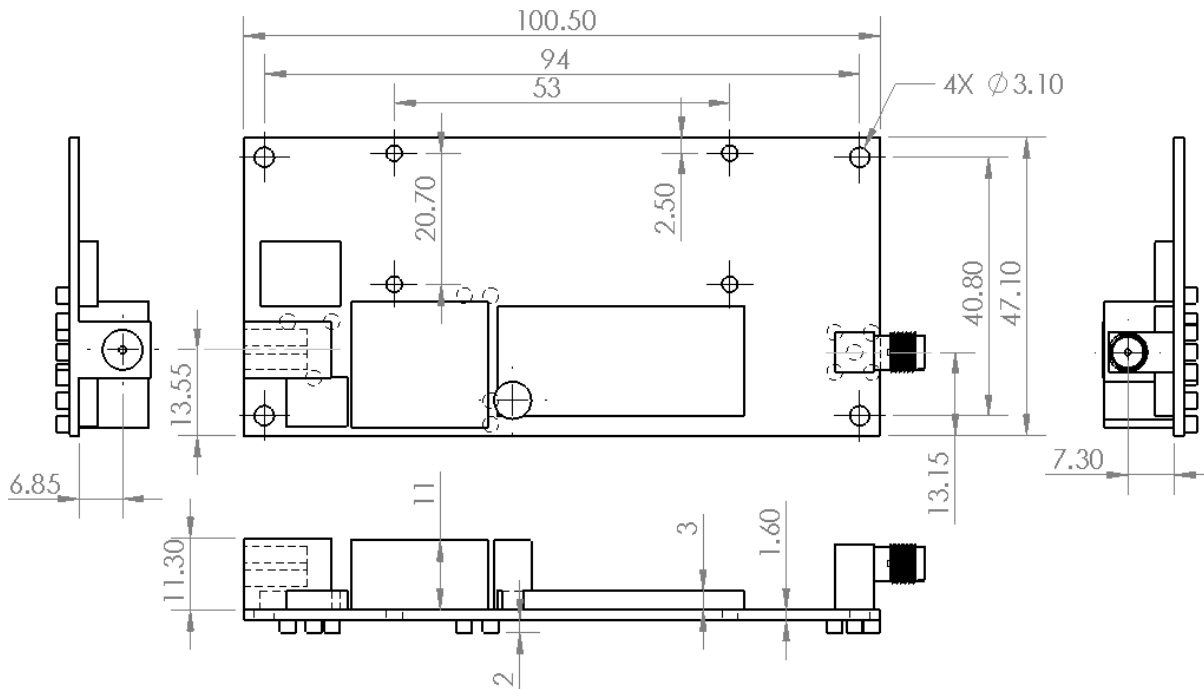

*Product dimensions may change without notice. This is sometimes required for non-standard specifications.

60 kHz Repetition Rate NanoSpeed™ Switch Driver

(1x1, 1x2, 2x1 Dual Stage/High Power standard)



DATASHEET

Power Connector

P/N: SC1313-ND

Power Barrel Connector Jack 2.00mm ID (0.079"),
5.50mm OD (0.217") Through Hole, Right Angle

12V Wall Plug DC Power Supply Interface

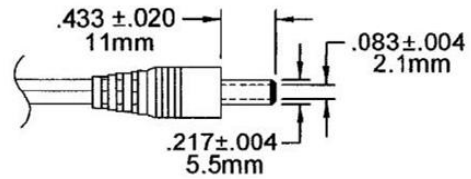
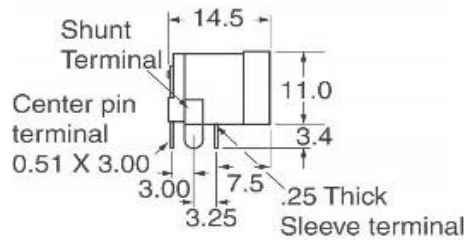

*Product dimensions may change without notice. This is sometimes required for non-standard specifications.

TTL Driver Interface (Our Circuit Diagram)

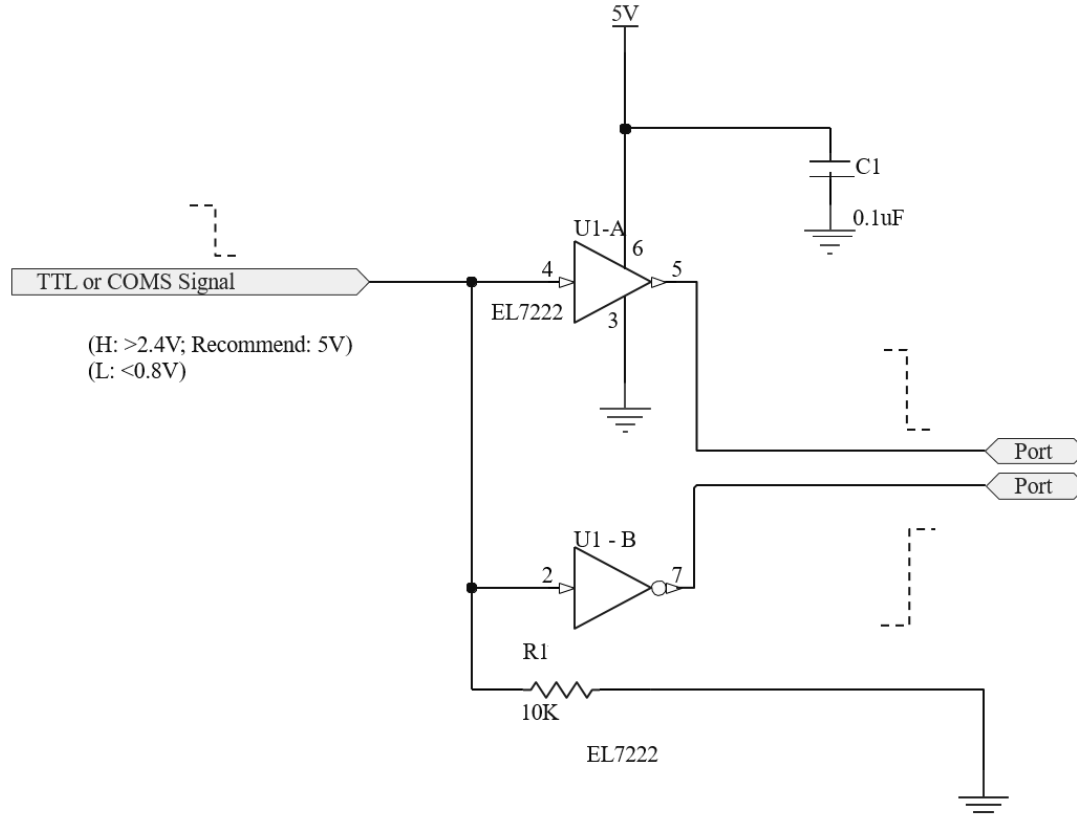

60 kHz Repetition Rate NanoSpeed™ Switch Driver

(1x1, 1x2, 2x1 Dual Stage/High Power standard)



DATASHEET

Ordering Information

Prefix	Switch Type	Function	Latching	Repeat rate	Footprint	# of Switch	Control Mode	DC supply
SWDR-	Standard DSS ^[1] = 2	1x1 = 1a Special=00	Non = 2	60kHz = 6	Standard = 1 Special = 0		TTL = 1 Special = 0	12VDC = 1 Special = 0

NOTE:

☐ This driver is intended mounted with specific switches, tuned, and tested prior to shipping. It is not designed to be sold separately.

Optical Power Handling vs Wavelength For Single-Mode Fibers

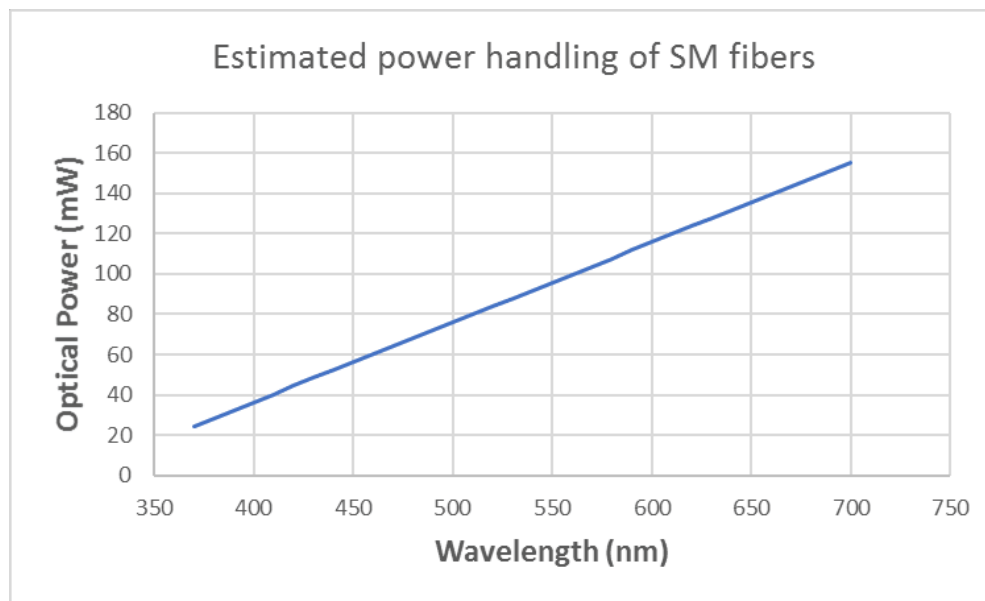

Operation Manual

1. Connect a control signal to the SMA connector on the PCB.
2. Attach the accompanied power supply (typically a wall-pluggable unit).
3. The device should then function properly.

Note: Do not alter device factory settings.